



# SMC Plastic-Encapsulate Diodes

## MURS420 Super Fast Recovery Rectifier Diodes

### Features

- $I_{F(AV)}$  4A
- $V_{RRM}$  200V
- High surge current capability
- Polarity: Color band denotes cathode

### Applications

- Rectifier

### Marking

- MURS420

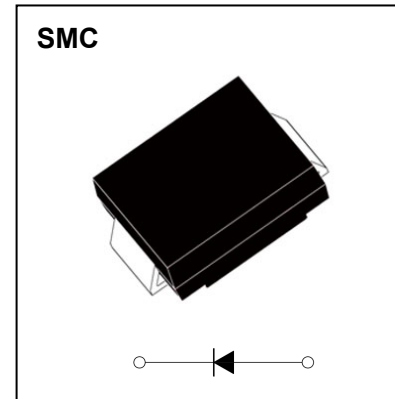

### Limiting Values (Absolute Maximum Rating)

Item	Symbol	Unit	Test Conditions	MURS420
Repetitive Peak Reverse Voltage	$V_{RRM}$	V		200
Maximum RMS Voltage	$V_{RMS}$	V		140
Average Forward Current	$I_{F(AV)}$	A	60Hz Half-sine wave, Resistance load, $T_L=100^\circ\text{C}$	4.0
Surge(Non-repetitive)Forward Current	$I_{FSM}$	A	60Hz Half-sine wave, 1 cycle, $T_a=25^\circ\text{C}$	120
Operation Junction and Storage Temperature Range	$T_J, T_{STG}$	$^\circ\text{C}$		-55 ~ +150

### Electrical Characteristics (T=25 °C Unless otherwise specified )

Item	Symbol	Unit	Test Condition	MURS420	
Peak Forward Voltage	$V_F$	V	$I_F=4.0\text{A}$	0.875 (Typ) 0.90 (Max)	
Reverse recovery time	$t_r$	ns	$I_F=0.5\text{A}, I_R=1.0\text{A}$ $I_{rr}=0.25\text{A}$	25	
Peak Reverse Current	$I_{RRM1}$	$\mu\text{A}$	$V_{RM}=V_{RRM}$	$T_a = 25^\circ\text{C}$	0.5
	$I_{RRM2}$			$T_a = 125^\circ\text{C}$	10
Thermal Resistance(Typical)	$R_{\theta J-A}$	$^\circ\text{C/W}$	Between junction and ambient	20 <sup>1)</sup>	
	$R_{\theta J-L}$		Between junction and terminal	12 <sup>1)</sup>	

### Notes:

Thermal resistance from junction to ambient and from junction to lead mounted on P.C.B. with 0.2" x 0.2" (5.0 mm x 5.0 mm) copper pad areas

# Typical Characteristics

FIG.1: FORWARD CURRENT DERATING CURVE

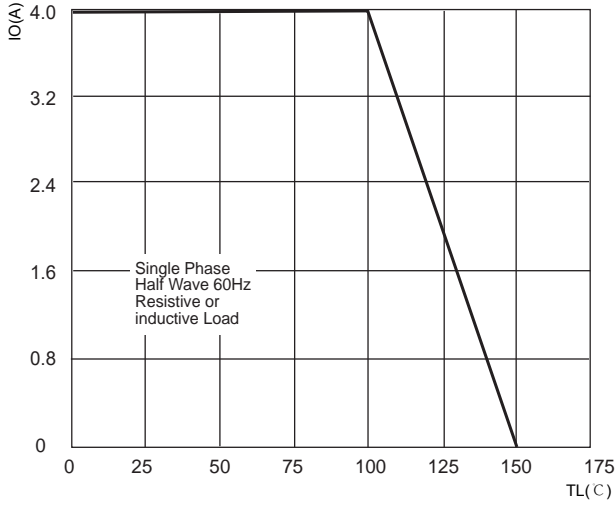

FIG.2: MAXIMUM NON-REPETITIVE FORWARD URGE CURRENT

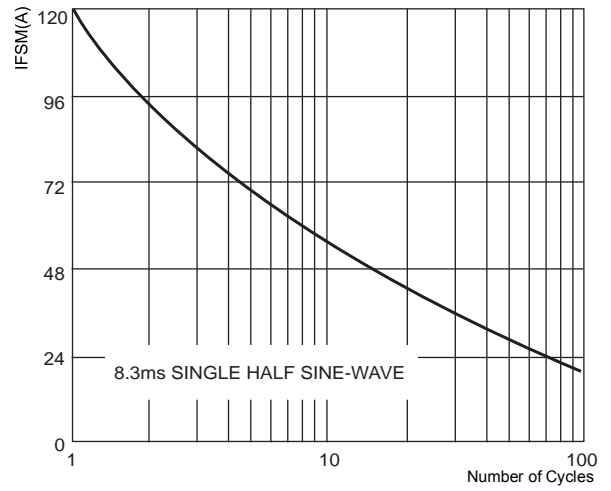

FIG.3: TYPICAL FORWARD CHARACTERISTICS

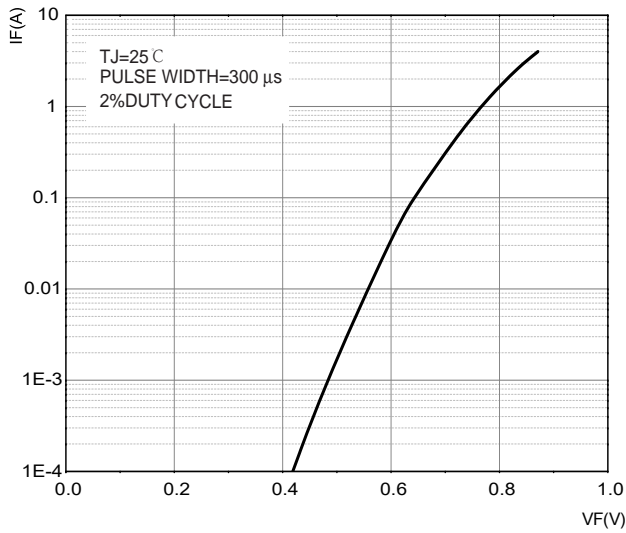

FIG.4: TYPICAL REVERSE CHARACTERISTICS

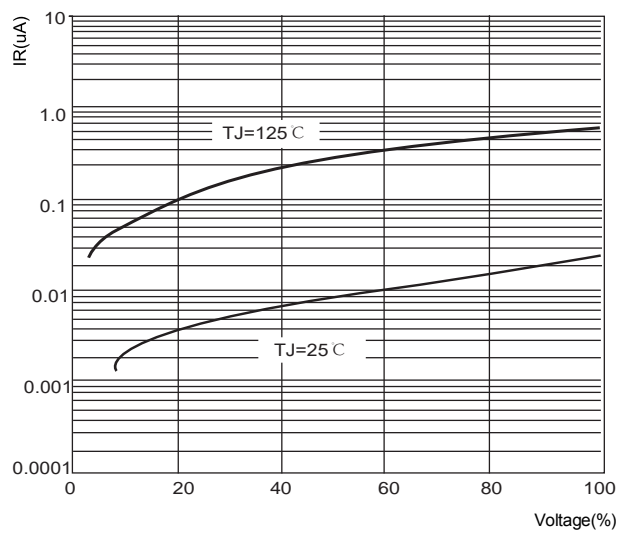
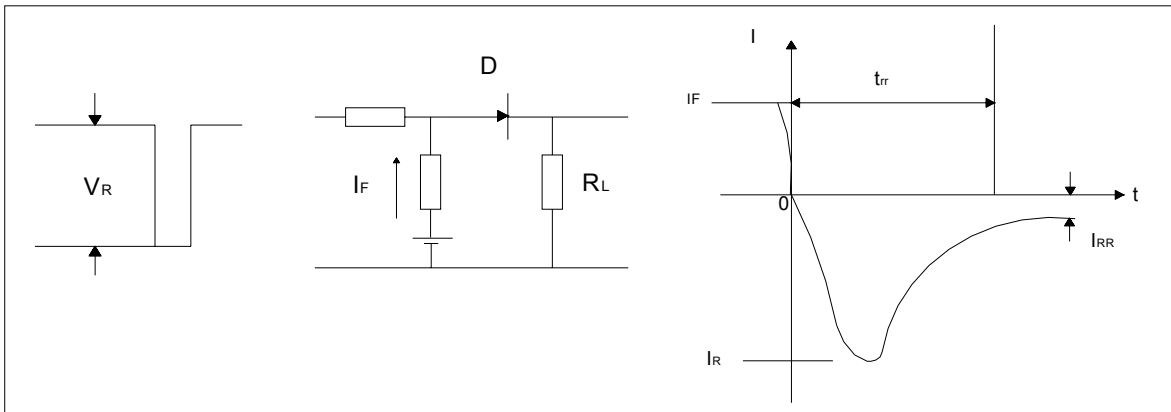
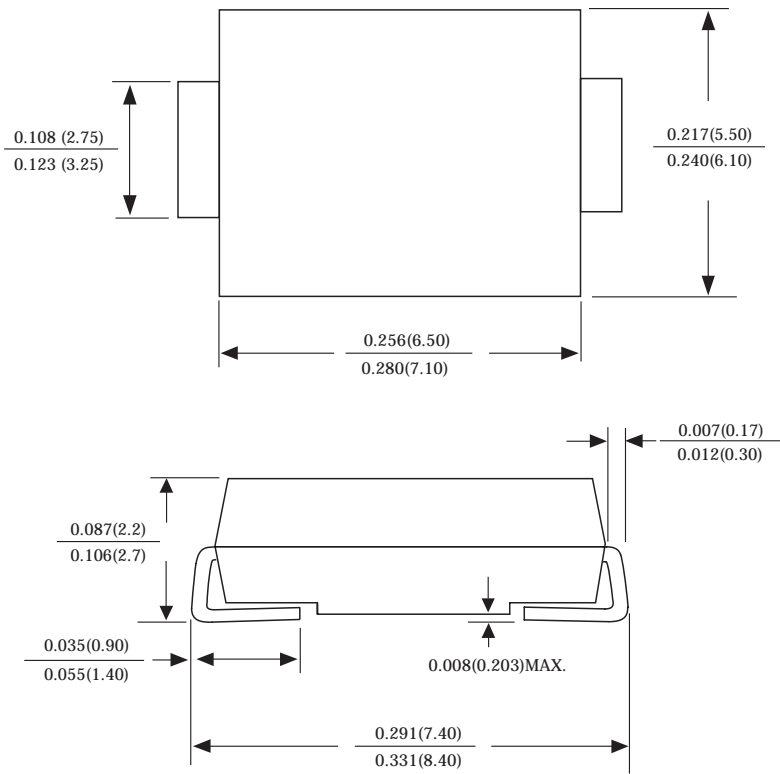

FIG.5: Diagram of circuit and Testing wave form of reverse recovery time



## SMC Package Outline Dimensions



Dimensions in inches and (millimeters)

## SMC Suggested Pad Layout

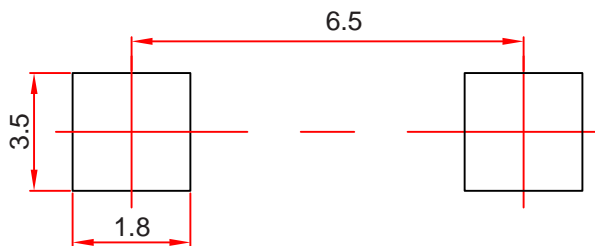

**Note:**

1. Controlling dimension: in millimeters.
2. General tolerance:  $\pm 0.05$ mm.
3. The pad layout is for reference purposes only.

## Reel Taping Specifications For Surface Mount Devices- SMC

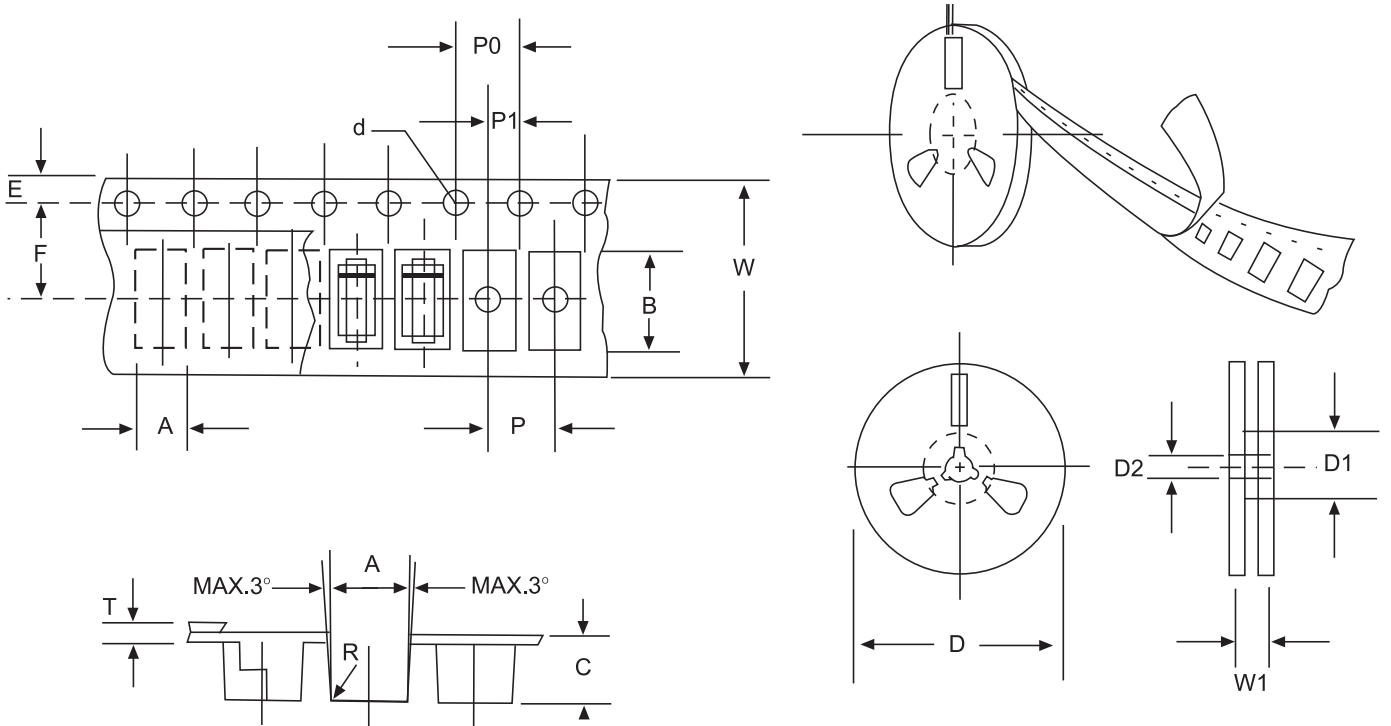

**FIG: CONFIGURATION OF SURFACE MOUNTED DEVICES TAPING**

ITEM	SYMBOL	SMCG mm(inch)
Carrier width	A	6.05±0.1(0.238±0.004)
Carrier length	B	8.31±0.1(0.327±0.004)
Carrier depth	C	2.70±0.1(0.106±0.004)
Sprocket hole	d	1.55±0.05(0.061±0.002)
Reel outside diameter	D	330±2.0(13±0.079)
Reel inner diameter	D1	75 ±1.0 ( 2.95 ±0.039)
Feed hole diameter	D2	13±0.5(0.512±0.020)
Sprocket hole position	E	1.75±0.1(0.069±0.004)
Punch hole position	F	7.65±0.05(0.301±0.002)
Punch hole pitch	P	8.0±0.1(0.315±0.004)
Sprocket hole pitch	P0	4.0±0.1(0.157±0.004)
Embossment center	P1	2.0±0.1(0.079±0.004)
Total tape thickness	T	0.3±0.1(0.012±0.004)
Tape width	W	16.0±0.2(0.630±0.008)
Reel width	W1	24.0±2.0(0.945±0.079)

NOTE: Devices are packed in accordance with EIA standard RS-481-A and specification given above.