



## SMA Plastic-Encapsulate Diodes

### MURS220 THRU MURS260 Super Fast Recovery Rectifier Diodes

#### Features

- $I_{F(AV)}$         2A
- $V_{RRM}$          200V-600V
- High surge current capability
- Polarity: Color band denotes cathode

#### Applications

- Rectifier

#### Marking

- MURS2X0
- X : From 2 to 6

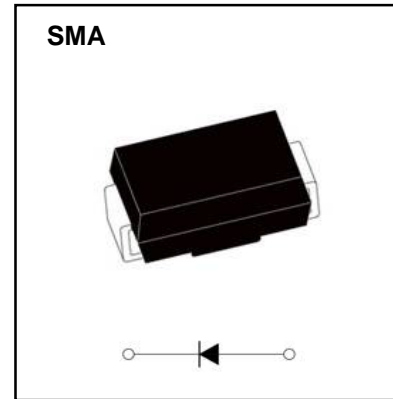

#### Limiting Values (Absolute Maximum Rating)

Item	Symbol	Unit	Test Conditions	MURS2		
				20	40	60
Repetitive Peak Reverse Voltage	$V_{RRM}$	V		200	400	600
Maximum RMS Voltage	$V_{RMS}$	V		140	280	420
Average Forward Current	$I_{F(AV)}$	A	60Hz Half-sine wave, Resistance load, $T_a=120\text{ }^\circ\text{C}$	2.0		
Surge(Non-repetitive)Forward Current	$I_{FSM}$	A	60Hz Half-sine wave, 1 cycle, $T_a=25\text{ }^\circ\text{C}$	50		
Operation Junction and Storage Temperature Range	$T_J, T_{STG}$	$^\circ\text{C}$		-55 ~ +150		

#### Electrical Characteristics (T=25 °C Unless otherwise specified )

Item	Symbol	Unit	Test Condition	MURS2		
				20	40	60
Peak Forward Voltage	$V_F$	V	$I_F=2.0\text{A}$	0.95	1.25	1.45
Reverse recovery time	$t_r$	ns	$I_F=0.5\text{A}, I_R=1.0\text{A}$ $I_{rr}=0.25\text{A}$	25	50	
Peak Reverse Current	$I_{RRM1}$	$\mu\text{A}$	$V_{RM}=V_{RRM}$	$T_a=25\text{ }^\circ\text{C}$		
	$I_{RRM2}$			$T_a=100\text{ }^\circ\text{C}$		
Thermal Resistance(Typical)	$R_{\theta J-A}$	$^\circ\text{C/W}$	Between junction and ambient	55 <sup>(1)</sup>		
	$R_{\theta J-L}$		Between junction and terminal	17 <sup>(1)</sup>		

#### Notes:

Thermal resistance from junction to ambient and from junction to lead mounted on P.C.B. with 0.2" x 0.2" (5.0 mm x 5.0 mm) copper pad areas

# Typical Characteristics

FIG.1: FORWARD CURRENT DERATING CURVE

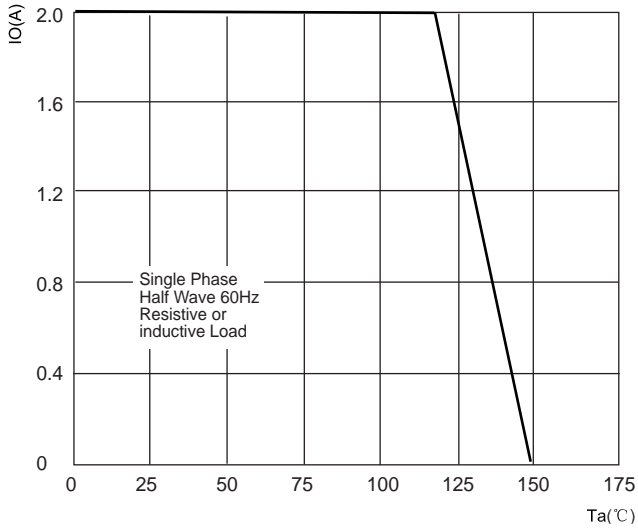

FIG.2: MAXIMUM NON-REPETITIVE FORWARD URGE CURRENT

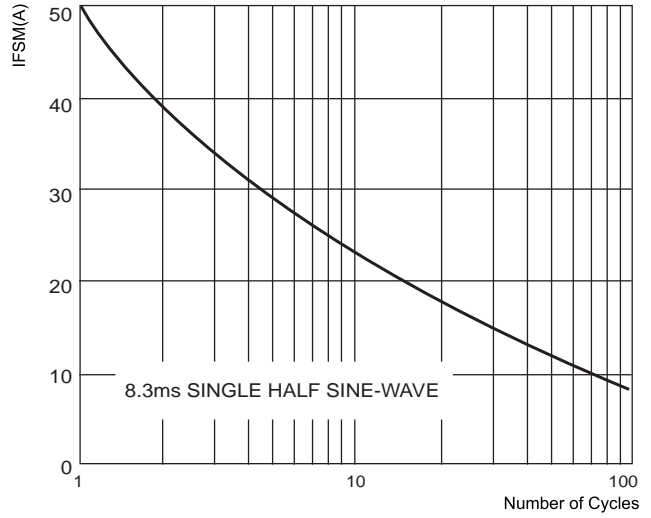

FIG.3: TYPICAL FORWARD CHARACTERISTICS

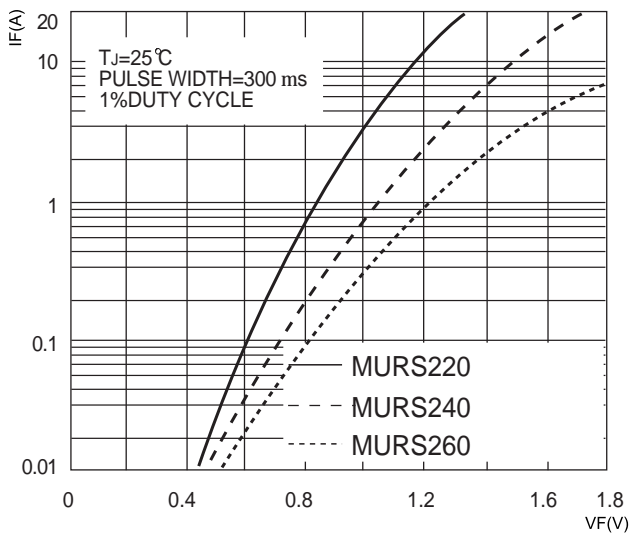

FIG.4: TYPICAL REVERSE CHARACTERISTICS

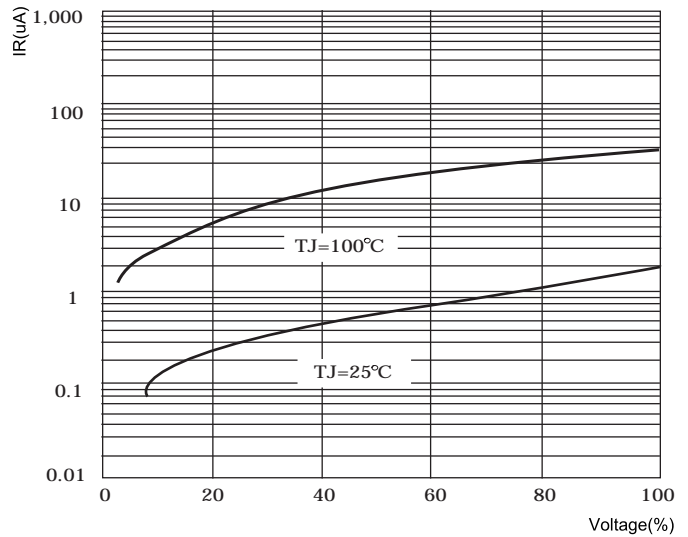
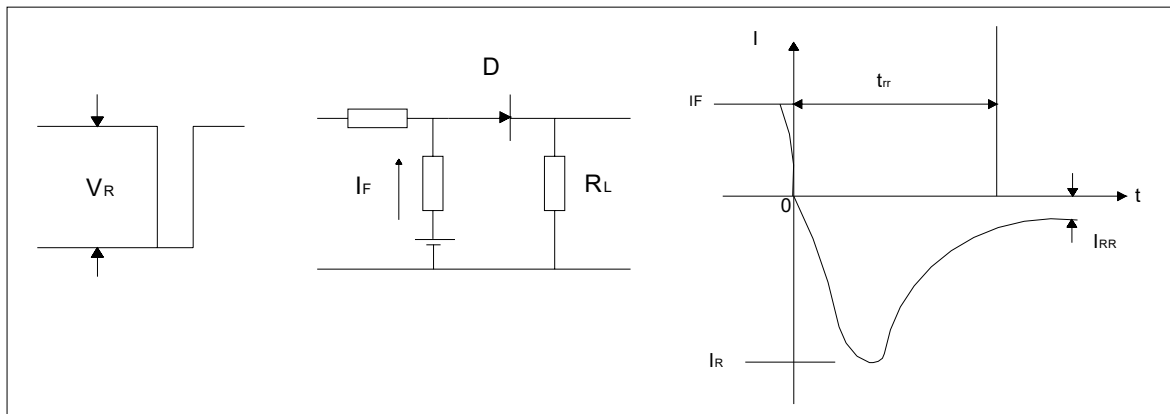

FIG.5: Diagram of circuit and Testing wave form of reverse recovery time



---

## SMA Package Outline Dimensions

---

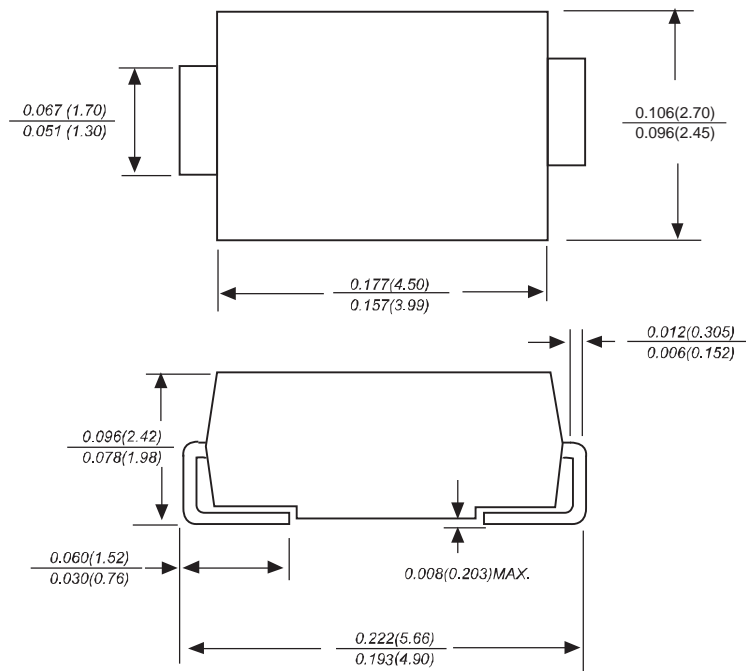

Dimensions in inches and (millimeters)

---

## SMA Suggested Pad Layout

---

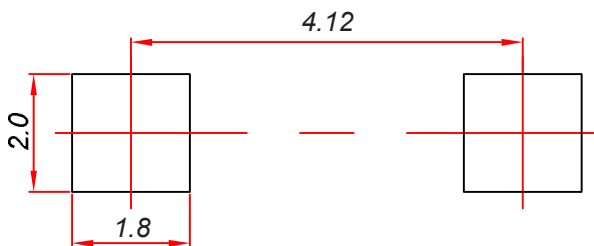

**Note:**

1. Controlling dimension: in millimeters.
2. General tolerance:  $\pm 0.05mm$ .
3. The pad layout is for reference purposes only.

## Reel Taping Specifications For Surface Mount Devices- SMA

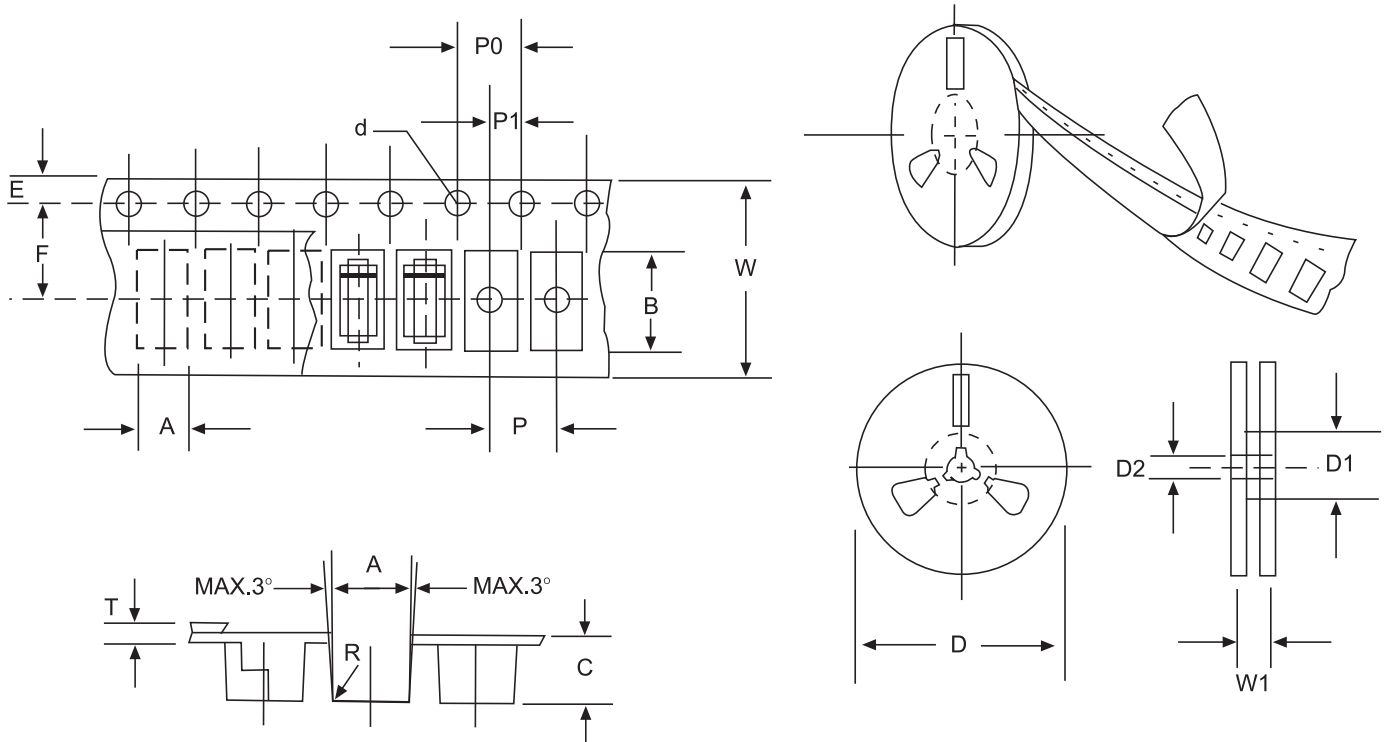

**FIG: CONFIGURATION OF SURFACE MOUNTED DEVICES TAPING**

ITEM	SYMBOL	SMAG mm(inch)
Carrier width	A	2.79±0.1(0.110±0.004)
Carrier length	B	5.33±0.1(0.210±0.004)
Carrier depth	C	2.36±0.1(0.093±0.004)
Sprocket hole	d	1.55±0.05(0.061±0.002)
Reel outside diameter	D	279±2.0 (11± 0.079)
Reel inner diameter	D1	75 ±1.0 ( 2.95 ±0.039)
Feed hole diameter	D2	13±0.5(0.512±0.020)
Sprocket hole position	E	1.75±0.1(0.069±0.004)
Punch hole position	F	5.5±0.05(0.217±0.002)
Punch hole pitch	P	4.0±0.1(0.157±0.004)
Sprocket hole pitch	P0	4.0±0.1(0.157±0.004)
Embossment center	P1	2.0±0.1(0.079±0.004)
Totall tape thickness	T	0.28±0.02(0.011±0.0008)
Tape width	W	12.0±0.2(0.472±0.008)
Reel width	W1	16.8±2.0(0.661±0.079)

NOTE: Devices are packed in accordance with EIA standard RS-481-A and specification given above.