



SMB Plastic-Encapsulate Diodes

MURS120 THRU MURS160 Super Fast Recovery Rectifier Diodes

Features

- $I_{F(AV)}$ 1A
- V_{RRM} 200V-600V
- High surge current capability
- Polarity: Color band denotes cathode

Applications

- Rectifier

Marking

- MURS1X0
- X : From 2 to 6

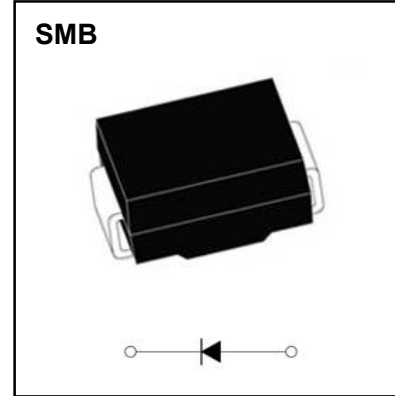

Limiting Values (Absolute Maximum Rating)

Item	Symbol	Unit	Test Conditions	MUR		
				S120	S140	S160
Repetitive Peak Reverse Voltage	V_{RRM}	V		200	400	600
Maximum RMS Voltage	V_{RMS}	V		140	280	420
Average Forward Current	$I_{F(AV)}$	A	60Hz Half-sine wave, Resistance load, $T_a=100^\circ\text{C}$	1.0		
Surge(Non-repetitive)Forward Current	I_{FSM}	A	60Hz Half-sine wave, 1 cycle, $T_a=25^\circ\text{C}$	30		
Operation Junction and Storage Temperature Range	T_J, T_{STG}	$^\circ\text{C}$		-55 ~ +150		

Electrical Characteristics ($T=25^\circ\text{C}$ Unless otherwise specified)

Item	Symbol	Unit	Test Condition	MUR		
				S120	S140	S160
Peak Forward Voltage	V_{FM}	V	$I_{FM}=1.0\text{A}$	0.875	1.25	
Peak Reverse Current	I_{RRM1}	μA	$V_{RM}=V_{RRM}$	2	5	
	I_{RRM2}				50	
Reverse recovery time	t_{rr}	ns	$I_F=0.5\text{A}, I_R=1.0\text{A}$ $I_{rr}=0.25\text{A}$	25	50	
Thermal Resistance(Typical)	$R_{\theta J-A}$	$^\circ\text{C}/\text{W}$	Between junction and ambient	60		
	$R_{\theta J-L}$		Between junction and lead	20		

Notes:

Thermal resistance from junction to ambient and from junction to lead mounted on P.C.B. with 0.2" x 0.2" (5.0 mm x 5.0 mm) copper pad areas

Typical Characteristics

FIG.1: FORWARD CURRENT DERATING CURVE

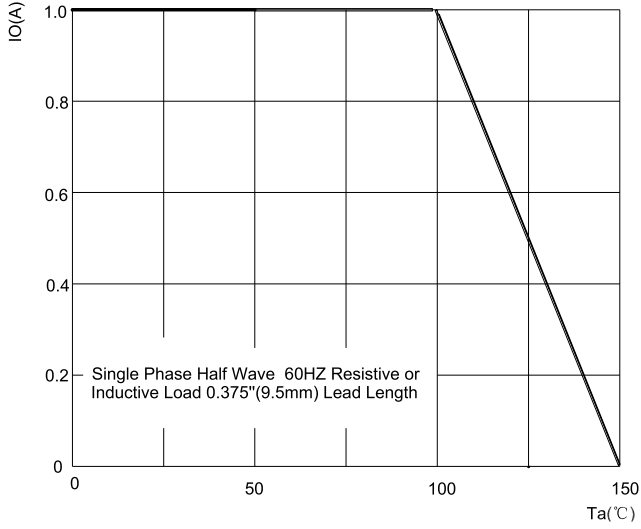

FIG.2: MAXIMUM NON-REPETITIVE FORWARD URGE CURRENT

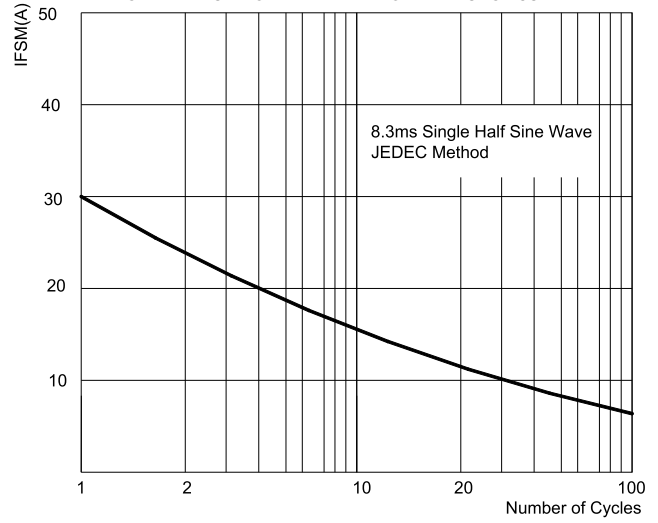

FIG.3: TYPICAL FORWARD CHARACTERISTICS

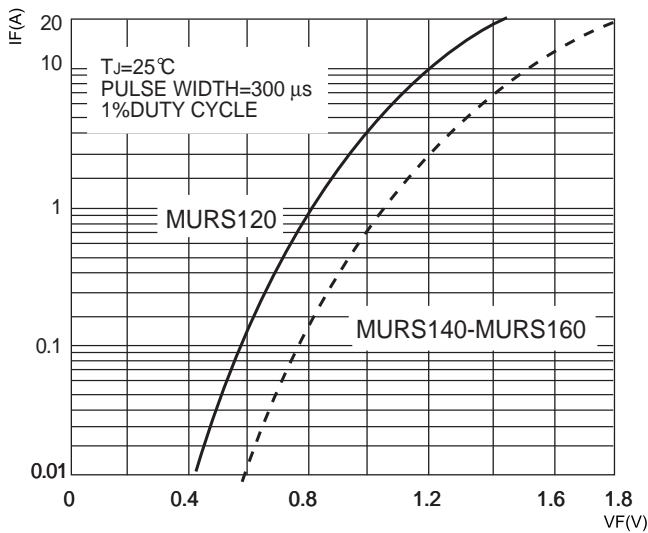

FIG.4: TYPICAL REVERSE CHARACTERISTICS

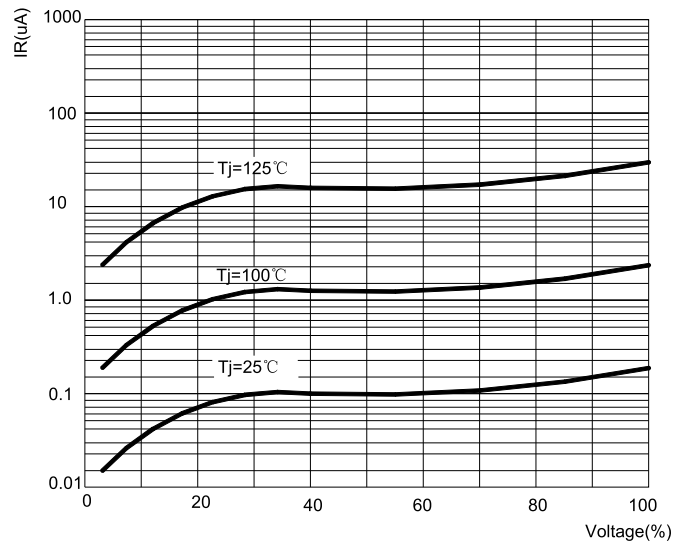
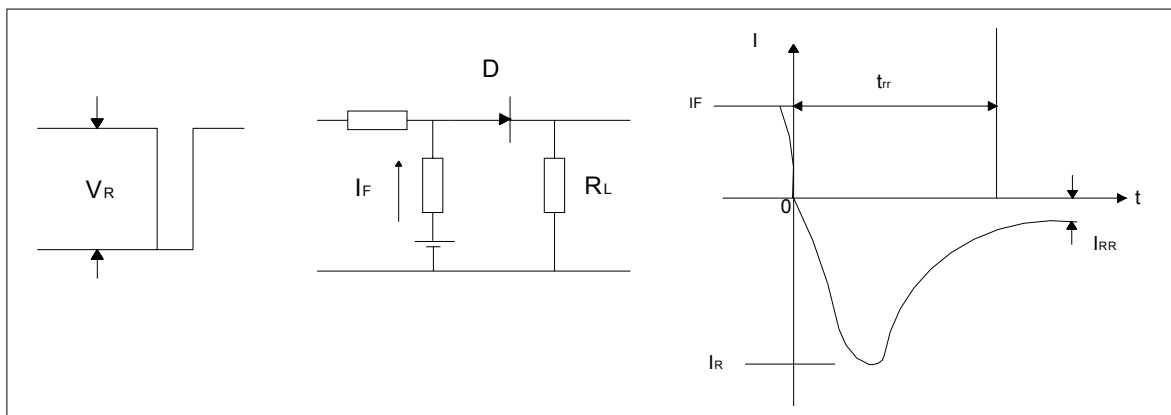
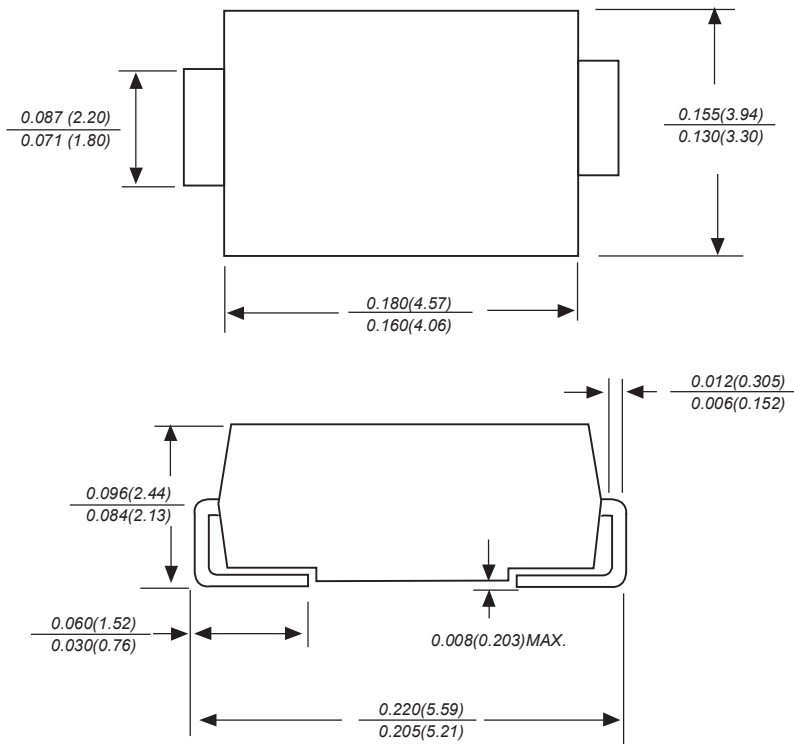

FIG.5: Diagram of circuit and Testing wave form of reverse recovery time



SMB Package Outline Dimensions



Dimensions in inches and (millimeters)

SMB Suggested Pad Layout

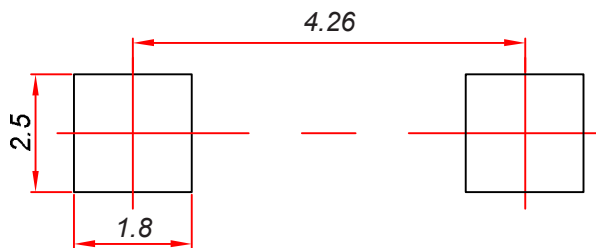

Note:

1. Controlling dimension: in millimeters.
2. General tolerance: $\pm 0.05mm$.
3. The pad layout is for reference purposes only.

Reel Taping Specifications For Surface Mount Devices- SMB

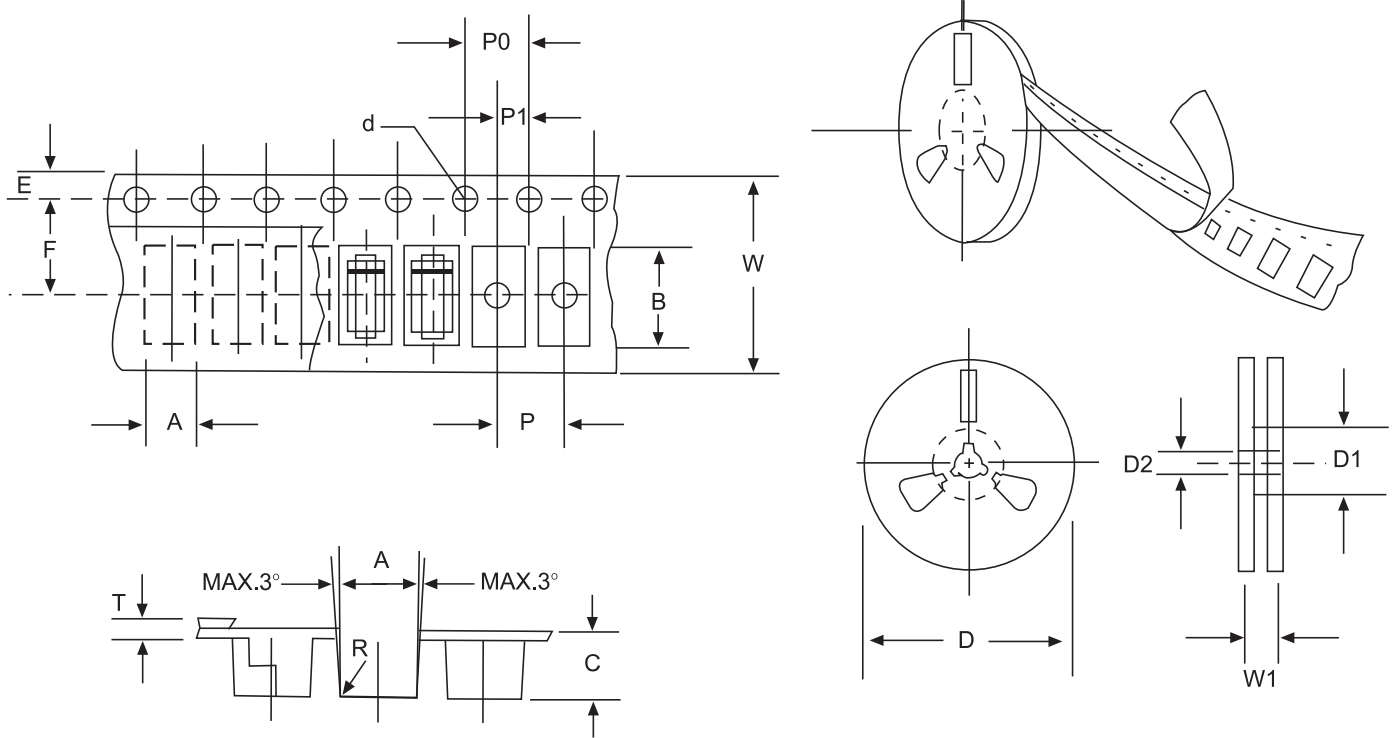

FIG: CONFIGURATION OF SURFACE MOUNTED DEVICES TAPING

ITEM	SYMBOL	SMBG mm(inch)
Carrier width	A	4.09±0.1(0.161±0.004)
Carrier length	B	5.82±0.1(0.229±0.004)
Carrier depth	C	2.50±0.1(0.100±0.004)
Sprocket hole	d	1.55±0.05(0.061±0.002)
Reel outside diameter	D	330±2.0(13±0.079)
Reel inner diameter	D1	75 ±1.0 (2.95 ±0.039)
Feed hole diameter	D2	13±0.5(0.512±0.020)
Sprocket hole position	E	1.75±0.1(0.069±0.004)
Punch hole position	F	5.65±0.05(0.222±0.002)
Punch hole pitch	P	8.0±0.1(0.315±0.004)
Sprocket hole pitch	P0	4.0±0.1(0.157±0.004)
Embossment center	P1	2.0±0.1(0.079±0.004)
Total tape thickness	T	0.32±0.1(0.013±0.004)
Tape width	W	12.0±0.2(0.472±0.008)
Reel width	W1	16.8±2.0(0.661±0.079)

NOTE: Devices are packed in accordance with EIA standard RS-481-A and specification given above.