

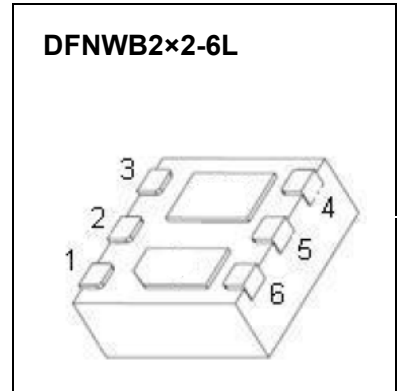

DFNWB2×2-6L Plastic-Encapsulat MOSFETS

MPD11 Dual P-Channel Power MOSFET

$V_{(BR)DSS}$	$R_{DS(on)}$ TYP	I_D
-20V	70mΩ@-4.5 V	-2.3 A
	110mΩ@-2.5 V	



General Description

The MPD11 uses advanced trench technology and design to Provide excellent $R_{DS(on)}$ with low gate charge. This device is suitable for use in DC-DC conversion applications.

FEATURE

- Low Profile for Easy Fit in Thin Environments
- Bidirectional Current Flow with Common Source Configuration

APPLICATIONS

- Optimized for Battery and Load Management Applications in Portable Equipment
- Li-Ion Battery Charging and Protection Circuits
- High Power Management in Portable , Battery Powered Products
- High Side Load Switch

MARKING:

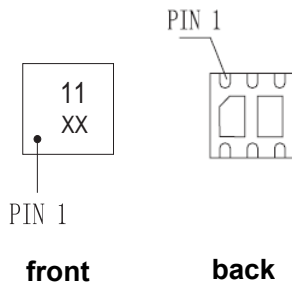

11 = Part No.
 Solid dot = Pin1 indicator.
 XX = Code.

Equivalent Circuit

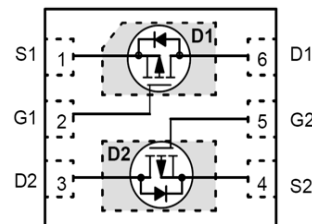

Maximum ratings ($T_a=25^\circ\text{C}$ unless otherwise noted)

Parameter	Symbol	Value	Unit
Drain-Source Voltage	V_{DS}	-20	V
Gate-Source Voltage	V_{GS}	±8	V
Continuous Drain Current	I_D	-2.3	A
Pulsed Drain Current ($t=300\mu\text{s}$)	I_{DM}	-10	A
Power Dissipation	P_D	0.35	W
Thermal Resistance from Junction to Ambient	$R_{\theta JA}$	357	$^\circ\text{C}/\text{W}$
Junction Temperature	T_J	150	$^\circ\text{C}$
Storage Temperature	T_{STG}	-55~ +150	$^\circ\text{C}$

MOSFET ELECTRICAL CHARACTERISTICS

$T_a=25^\circ\text{C}$ unless otherwise specified

Parameter	Symbol	Test Condition	Min	Type	Max	Unit
Static Characteristics						
Drain-source breakdown voltage	$V_{(BR)DSS}$	$V_{GS} = 0V, I_D = -250\mu A$	-20			V
Zero gate voltage drain current	I_{DSS}	$V_{DS} = -16V, V_{GS} = 0V$			-1	μA
Gate-body leakage current	I_{GSS}	$V_{GS} = \pm 8V, V_{DS} = 0V$			± 100	nA
Gate threshold voltage	$V_{GS(th)}$	$V_{DS} = V_{GS}, I_D = -250\mu A$	-0.4	-0.7	-1	V
Drain-source on-resistance ^a	$R_{DS(on)}$	$V_{GS} = -4.5V, I_D = -3A$		70	110	m Ω
		$V_{GS} = -2.5V, I_D = -2A$		110	140	
Forward tranconductance ^a	g_{FS}	$V_{DS} = -5V, I_D = -2A$	5			S
Dynamic characteristics^b						
Input Capacitance	C_{iss}	$V_{DS} = -10V, V_{GS} = 0V, f = 1MHz$		405		pF
Output Capacitance	C_{oss}			75		
Reverse Transfer Capacitance	C_{rss}			55		
Gate resistance	R_g	$f = 1MHz$		6		Ω
Total Gate Charge	Q_g	$V_{DS} = -10V, V_{GS} = -2.5V, I_D = -3A$		3.3	12	nC
Gate-Source Charge	Q_{gs}			0.7		
Gate-Drain Charge	Q_{gd}			1.3		
Turn-on delay time	$t_{d(on)}$	$V_{DD} = -10V, V_{GEN} = -4.5V, I_D = -1A$ $R_L = 10\Omega, R_{GEN} = 1\Omega$		11		ns
Turn-on rise time	t_r			35		
Turn-off delay time	$t_{d(off)}$			30		
Turn-off fall time	t_f			10		
Source-Drain Diode characteristics						
Diode forward current	I_S	$T_c = 25^\circ\text{C}$			-2.3	A
Diode pulsed forward current ^a	I_{SM}				-10	A
Diode Forward voltage	V_{DS}	$V_{GS} = 0V, I_S = -1.3A$			-1.2	V

Notes :

a. Pulse Test : Pulse Width < 300 μs , Duty Cycle $\leq 2\%$.

b. Guaranteed by design, not subject to production testing.

Typical Characteristics

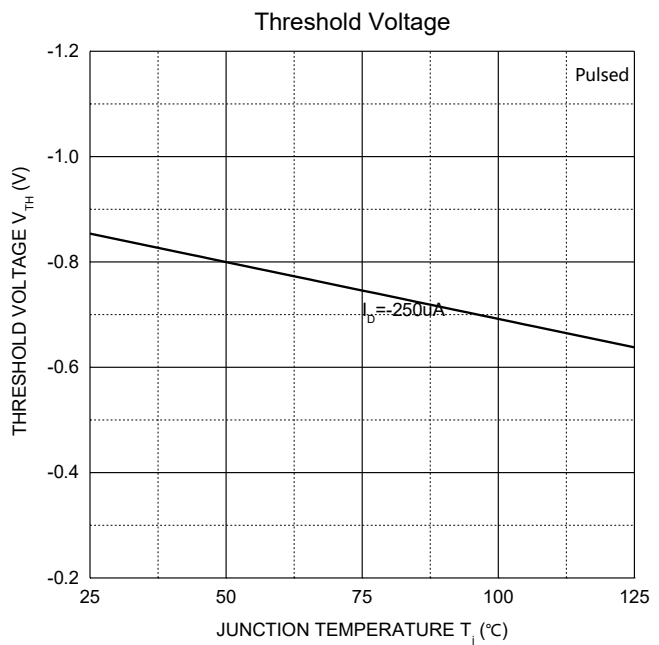
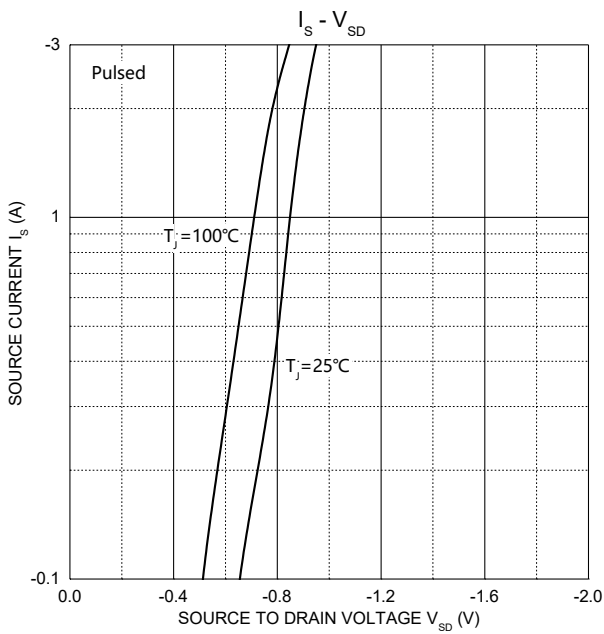
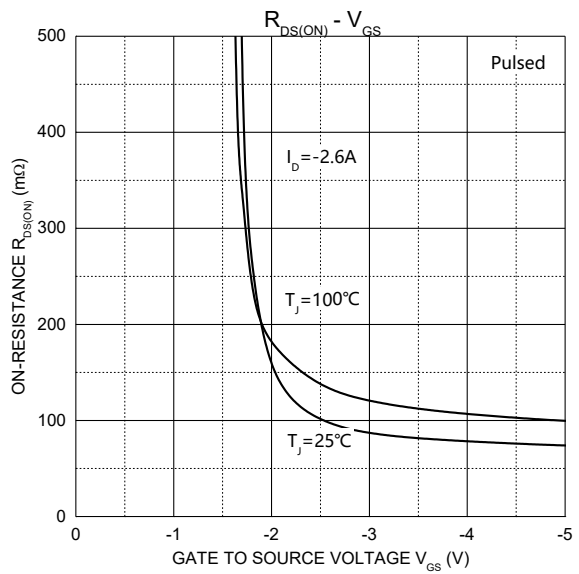
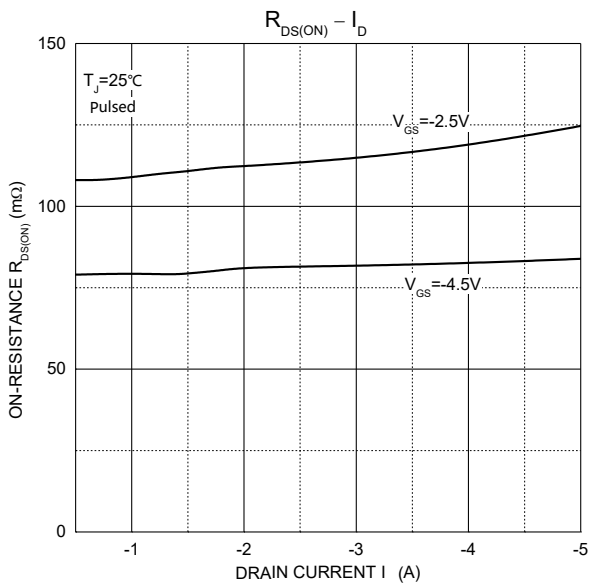
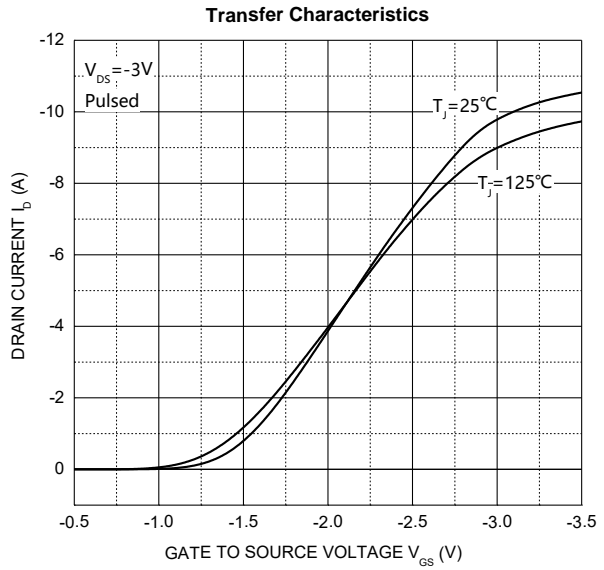
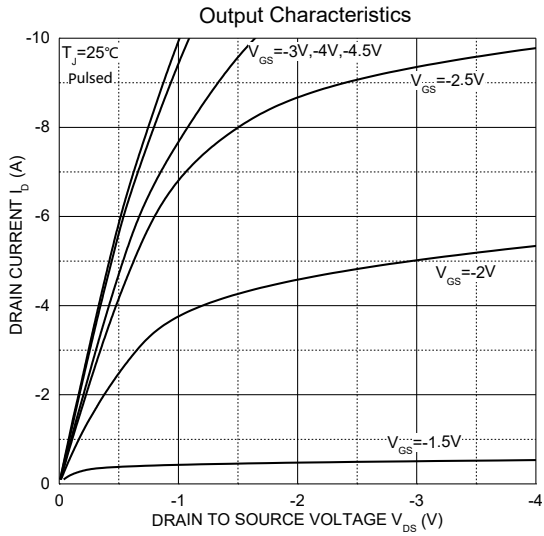

DFNWB2X2-6L-U Package Outline Dimensions

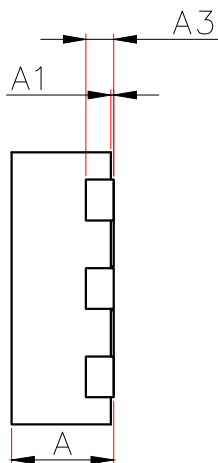
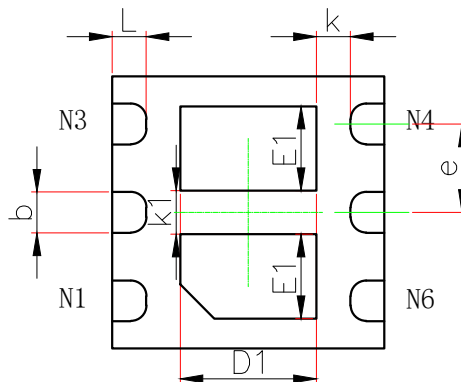
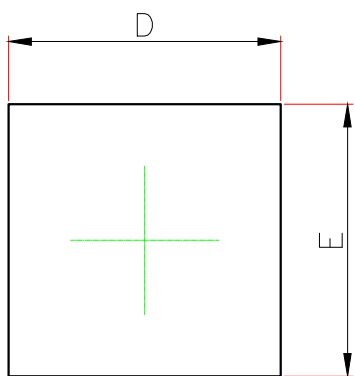

Symbol	Dimensions In Millimeters		Dimensions In Inches	
	MIN.	MAX.	MIN.	MAX.
A	0.700	0.800	0.028	0.031
A1	0.000	0.050	0.000	0.002
A3	0.203REF.		0.008REF.	
D	1.900	2.100	0.075	0.083
E	1.900	2.100	0.075	0.083
D1	0.900	1.100	0.035	0.043
E1	0.520	0.720	0.020	0.028
b	0.250	0.350	0.010	0.014
e	0.650TYP.		0.026TYP.	
k	0.200MIN.		0.008MIN.	
k1	0.320REF.		0.013REF.	
L	0.200	0.300	0.008	0.012

DFNWB2X2-6L-U Suggested Pad Layout

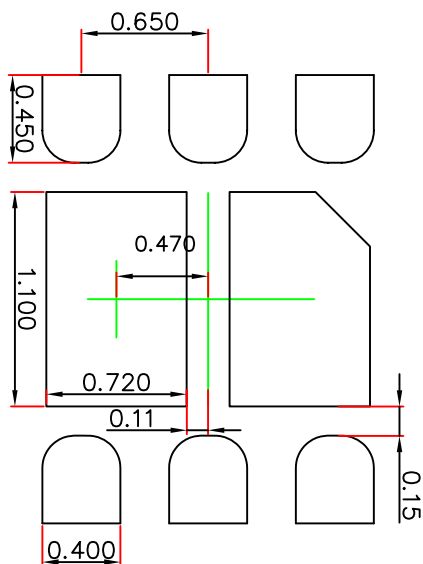

Note:

1. Controlling dimension: in millimeters.
2. General tolerance: ± 0.050 mm.
3. The pad layout is for reference purposes only.

DFNWB2X2-6L Tape and Reel

DFNWB2×2-6L Embossed Carrier Tape

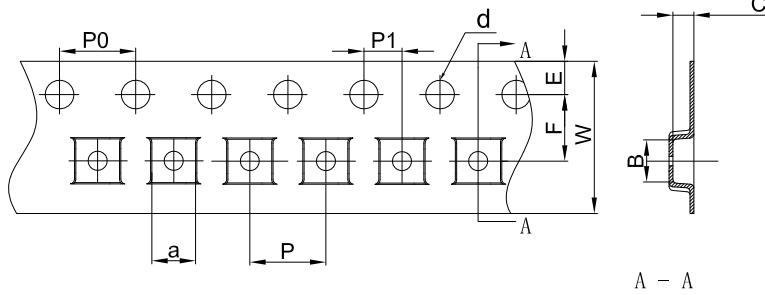

Packaging Description:

DFNWB2×2-6L parts are shipped in tape. The carrier tape is made from a dissipative (carbon filled) polycarbonate resin. The cover tape is a multilayer film (Heat Activated Adhesive in nature) primarily composed of polyester film, adhesive layer, sealant, and anti-static sprayed agent. These reeled parts in standard option are shipped with 3,000 units per 7" or 18.0cm diameter reel. The reels are clear in color and is made of polystyrene plastic (anti-static coated).

Dimensions are in millimeter

Pkg type	a	B	C	d	E	F	P0	P	P1	W
DFNWB2×2-6L	2.30	2.30	1.10	Ø1.50	1.75	3.50	4.00	4.00	2.00	8.00

DFNWB2×2-6L Tape Leader and Trailer

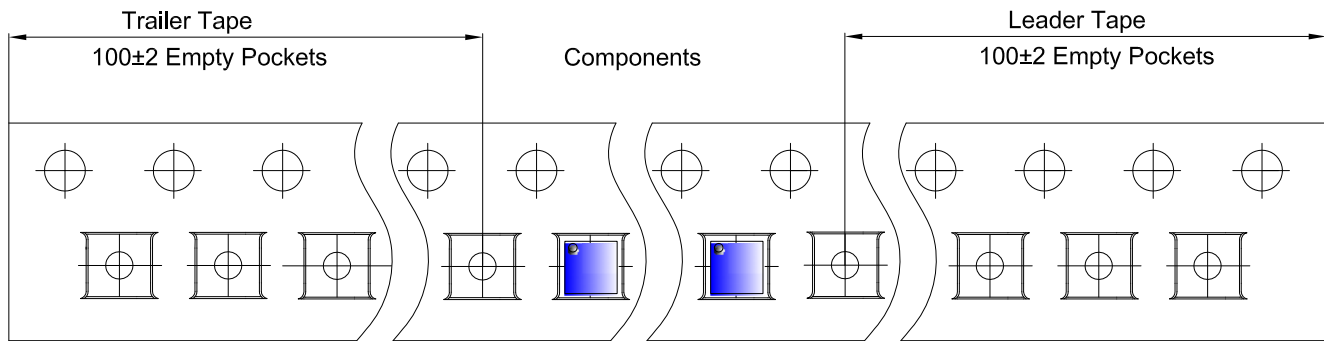

DFNWB2×2-6L Reel

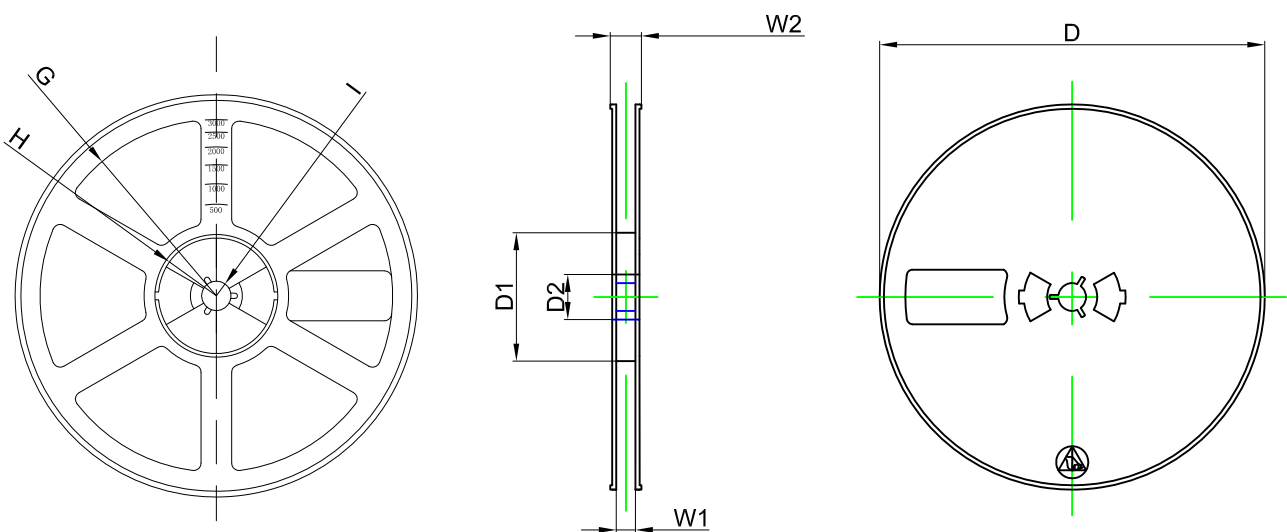

Dimensions are in millimeter

Reel Option	D	D1	D2	G	H	I	W1	W2
7" Dia	Ø180.00	60.00	13.00	R78.00	R25.60	R6.50	9.50	13.10

REEL	Reel Size	Box	Box Size(mm)	Carton	Carton Size(mm)	G.W.(kg)
3000 pcs	7 inch	30,000 pcs	203×203×195	120,000 pcs	438×438×220	