



# SMC Plastic-Encapsulate Diodes

## ES5A THRU ES5J Super Fast Recovery Rectifier Diodes

### Features

- $I_{F(AV)}$  5A
- $V_{RRM}$  50V-600V
- High surge current capability
- Polarity: Color band denotes cathode

### Applications

- Rectifier

### Marking

- ES5X
- X : From A To J

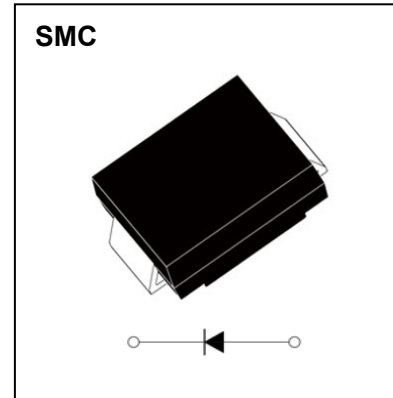

### Limiting Values(Absolute Maximum Rating)

Item	Symbol	Unit	Test Conditions	ES5							
				A	B	C	D	E	G	H	J
Repetitive Peak Reverse Voltage	$V_{RRM}$	V		50	100	150	200	300	400	500	600
Maximum RMS Voltage	$V_{RMS}$	V		35	70	105	140	210	280	350	420
Average Forward Current	$I_{F(AV)}$	A	60Hz Half-sine wave, Resistance load, $T_a=75^\circ\text{C}$	5.0							
Surge(Non-repetitive)Forward Current	$I_{FSM}$	A	60Hz Half-sine wave, 1 cycle, $T_a=25^\circ\text{C}$	150							
Operation Junction and Storage Temperature Range	$T_J, T_{STG}$	$^\circ\text{C}$		-55 ~ +150							

### Electrical Characteristics ( $T=25^\circ\text{C}$ Unless otherwise specified)

Item	Symbol	Unit	Test Condition	ES5							
				A	B	C	D	E	G	H	J
Peak Forward Voltage	$V_F$	V	$I_F=5.0\text{A}$	0.95			1.25		1.7		
Maximum reverse recovery time	$t_{rr}$	ns	$I_F=0.5\text{A}, I_R=1.0\text{A}, I_{rr}=0.25\text{A}$	35							
Peak Reverse Current	$I_{RRM1}$	$\mu\text{A}$	$V_{RM}=V_{RRM}$	$T_a=25^\circ\text{C}$				10			
	$I_{RRM2}$			$T_a=100^\circ\text{C}$				500			
Thermal Resistance(Typical)	$R_{\theta J-A}$	$^\circ\text{C}/\text{W}$	Between junction and ambient				47				
	$R_{\theta J-L}$		Between junction and terminal				12				

### Notes:

Thermal resistance from junction to ambient and from junction to lead mounted on P.C.B. with 0.30" x 0.30" (8.0 mm x 8.0 mm) copper pad areas

# Typical Characteristics

FIG.1: FORWARD CURRENT DERATING CURVE

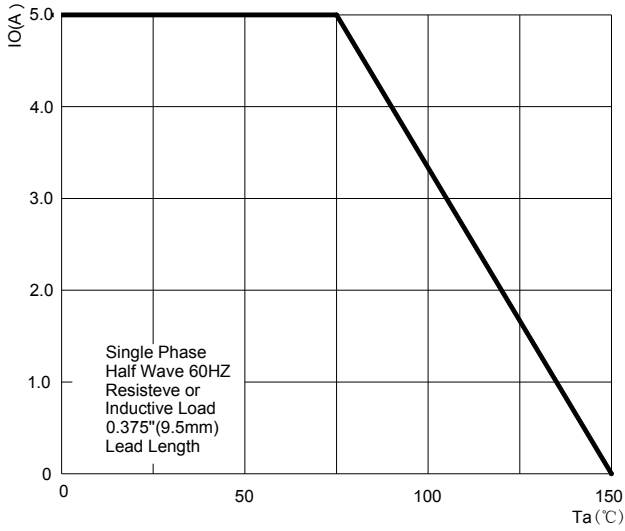
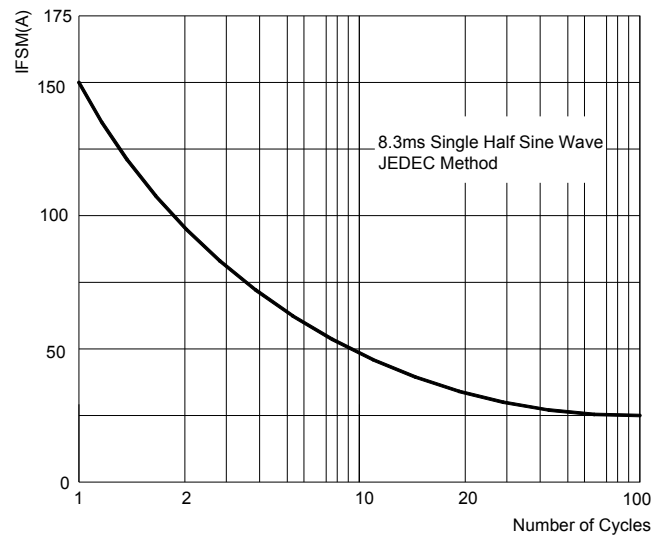

FIG.2: MAXIMUM NON-REPETITIVE FORWARD SURGE CURRENT



TYPICAL FORWARD CHARACTERISTICS

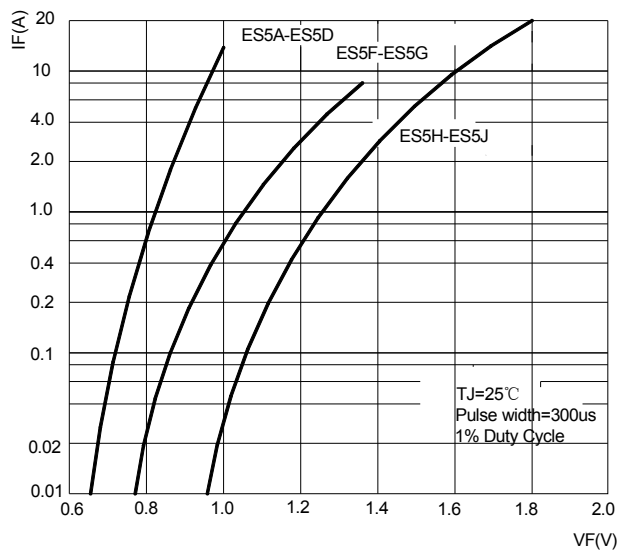

FIG.4: TYPICAL REVERSE CHARACTERISTICS

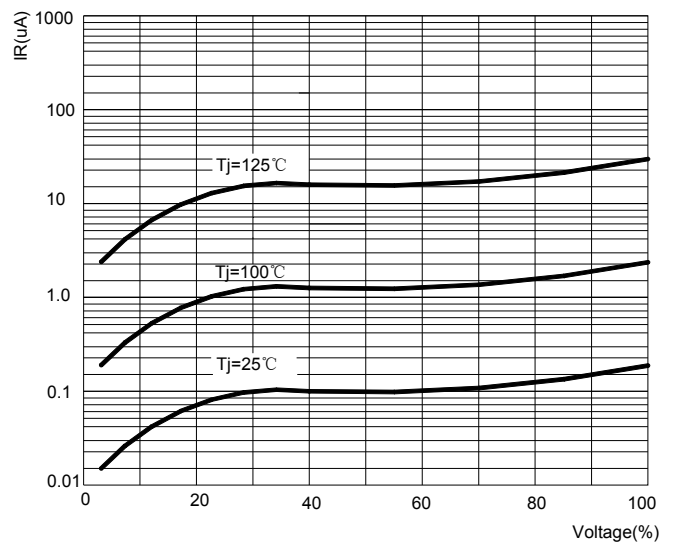
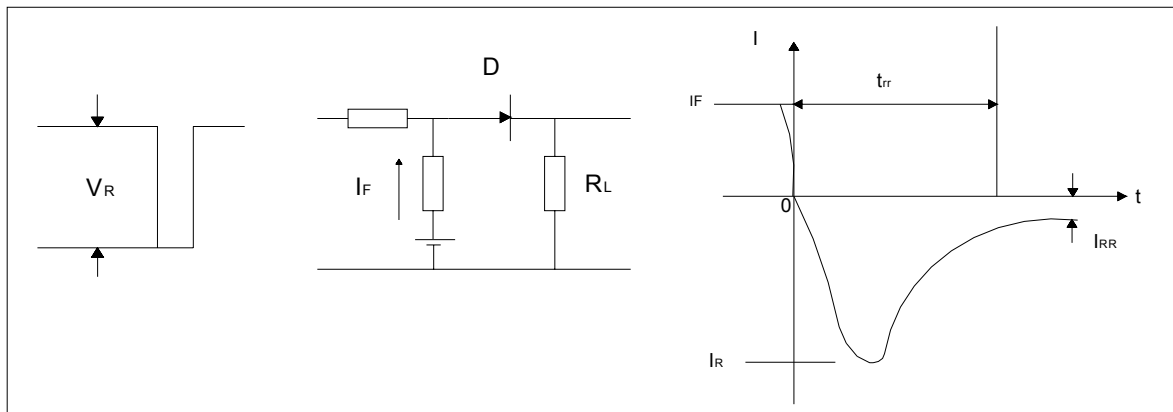

FIG.5: Diagram of circuit and Testing wave form of reverse recovery time



---

## SMC Package Outline Dimensions

---

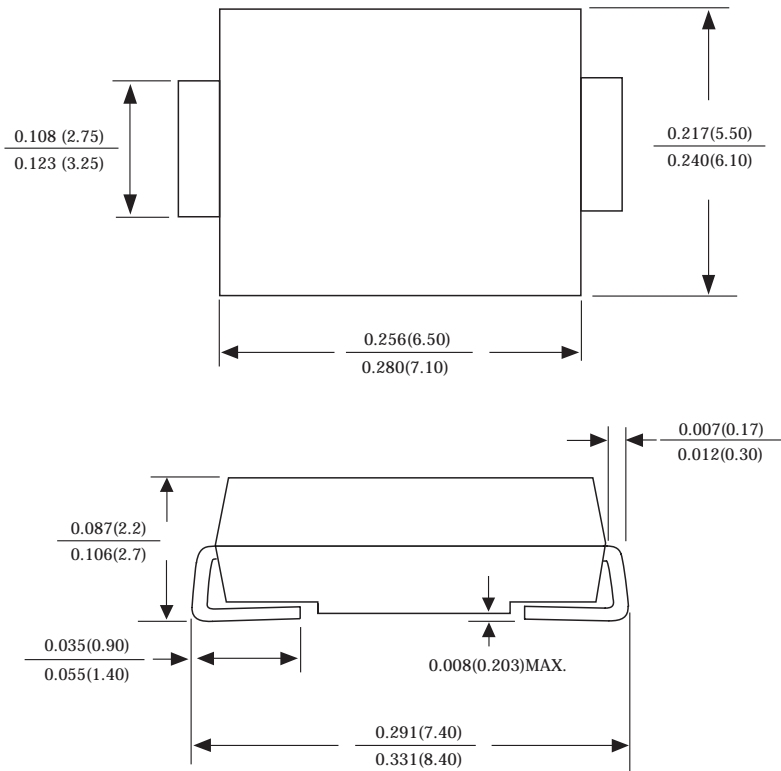

Dimensions in inches and (millimeters)

---

## SMC Suggested Pad Layout

---

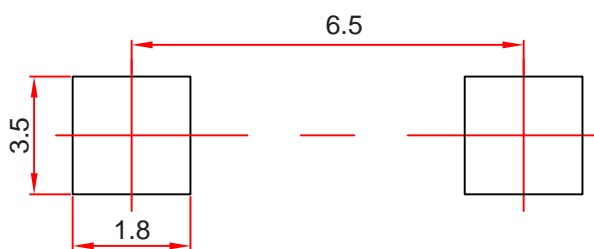

**Note:**

1. Controlling dimension: in millimeters.
2. General tolerance:  $\pm 0.05$ mm.
3. The pad layout is for reference purposes only.

# Reel Taping Specifications For Surface Mount Devices–SMC

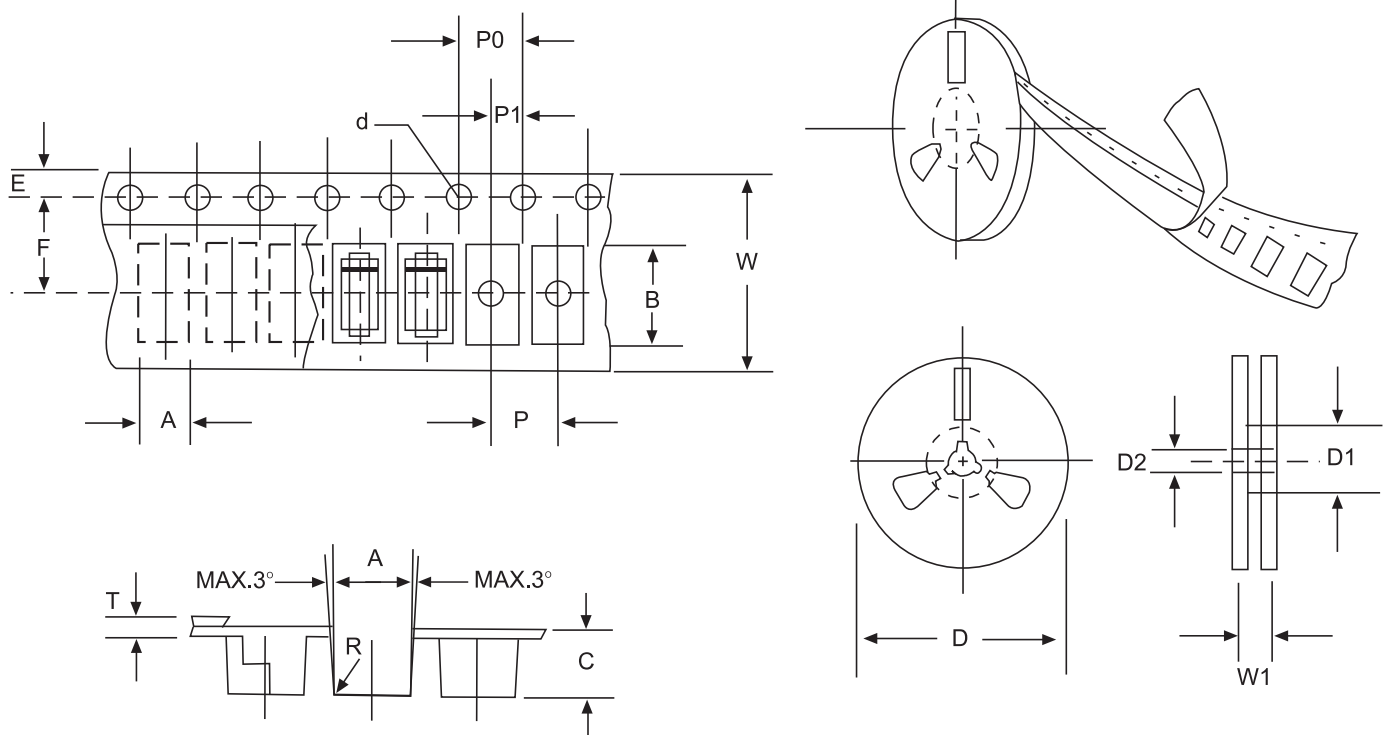

**FIG: CONFIGURATION OF SURFACE MOUNTED DEVICES TAPING**

ITEM	SYMBOL	SMCG mm(inch)
Carrier width	A	6.05±0.1(0.238±0.004)
Carrier length	B	8.31±0.1(0.327±0.004)
Carrier depth	C	2.70±0.1(0.106±0.004)
Sprocket hole	d	1.55±0.05(0.061±0.002)
Reel outside diameter	D	330±2.0(13±0.079)
Reel inner diameter	D1	75 ±1.0 ( 2.95 ±0.039)
Feed hole diameter	D2	13±0.5(0.512±0.020)
Strocket hole position	E	1.75 ±0.1(0.069±0.004)
Punch hole position	F	7.65±0.05(0.301±0.002)
Punch hole pitch	P	8.0±0.1(0.315±0.004)
Sprocket hole pitch	P0	4.0±0.1(0.157±0.004)
Embossment center	P1	2.0±0.1(0.079±0.004)
Totall tape thickness	T	0.3 ± 0.1 ( 0.012±0.004)
Tape width	W	16.0±0.2(0.630±0.008)
Reel width	W1	24.0±2.0(0.945±0.079)

NOTE: Devices are packed in accordance with EIA standard RS-481-A and specification given above.